

W. R. LANDFEAR.
MACHINE FOR LABELING SPOOLS.

No. 303,391.

Patented Aug. 12, 1884.

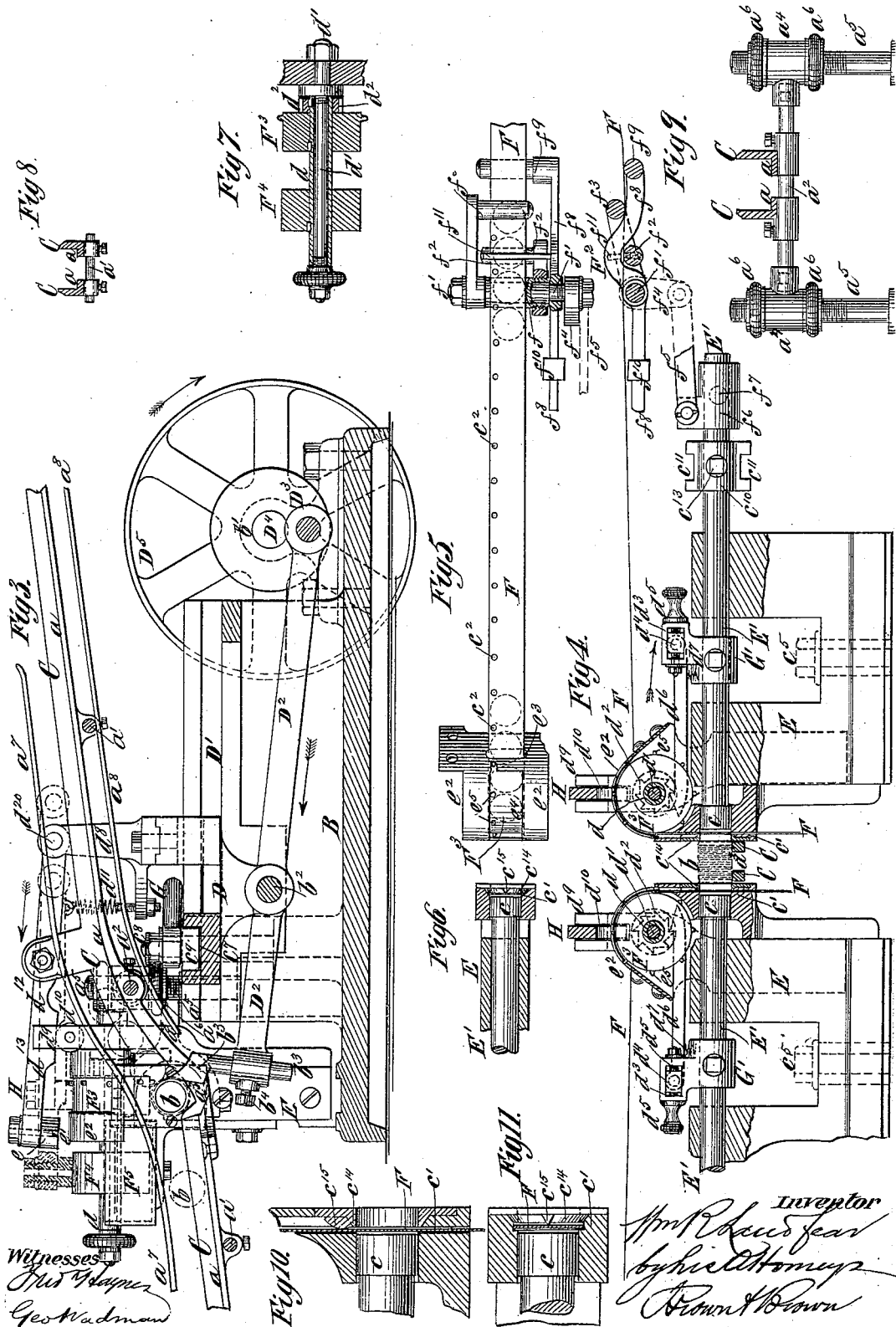

Witnesses
H. W. Wagner
Geo. Wadman

Inventor
W. R. Landfear
by
H. W. Wagner
Geo. Wadman

(No Model.)

4 Sheets—Sheet 3.

W. R. LANDFEAR.
MACHINE FOR LABELING SPOOLS.

No. 303,391.

Patented Aug. 12, 1884.

Fig. 12.

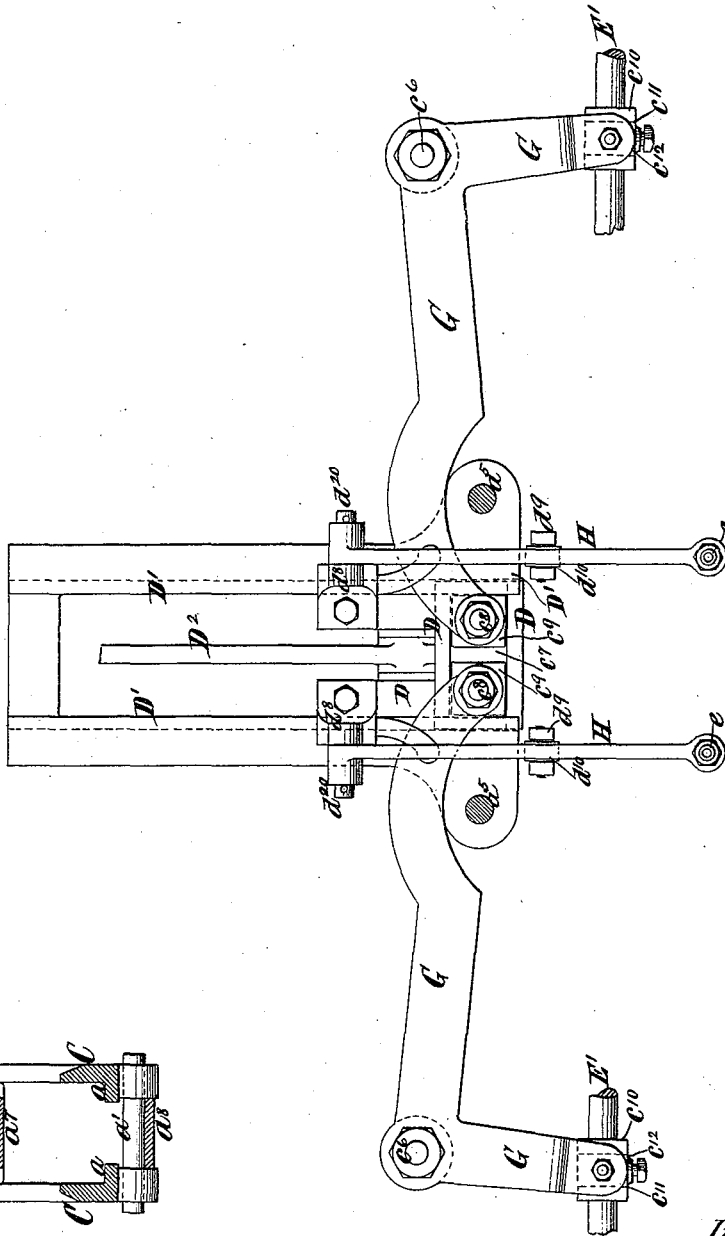
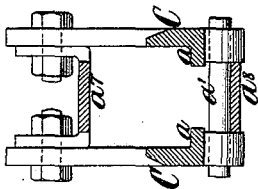

Fig. 8.*



Witnesses:

C. Hall
O. Sundgren

Inventor:

Wm. R. Landfear
by his Attyy
Brown & Brown

UNITED STATES PATENT OFFICE.

WILLIAM R. LANDFEAR, OF BROOKLYN, NEW YORK.

MACHINE FOR LABELING SPOOLS.

SPECIFICATION forming part of Letters Patent No. 303,391, dated August 12, 1884.

Application filed October 17, 1883. (No model.) Patented in England December 16, 1879, No. 5,147.

To all whom it may concern:

Be it known that I, WILLIAM R. LANDFEAR, of the city of Brooklyn, in the county of Kings and State of New York, have invented certain new and useful Improvements in Machines for Labeling Spools, of which the following is a specification.

Part of these improvements have been patented in Great Britain by Letters Patent No. 5,147, dated December 16, 1879, to Peter Joel Lävsey on a communication from myself and Timothy Merrick.

The object of my said improvements is to enable the labels—such as are commonly placed on the ends of spools of silk and other thread—to be applied more perfectly and expeditiously than has been possible with the methods and machines heretofore used.

Spool-labels are printed upon strips of paper, and the work to be performed in applying the labels is to apply adhesive substance to the labels, to cut them from the strip, and to secure them by pressure upon the ends of the spools.

In carrying out my invention I pursue a method which consists in applying adhesive substance to the labels while they are in the strip, and before cutting them out, in cutting or punching the labels from the strip by a reciprocating punch, and in applying the label to the spool by a continued longitudinal movement of the punch after it has completed the punching of the label from the strip.

The invention consists in the combination of oppositely-arranged dies, a spool-rest between them, feed-wheels arranged above said dies, and having a step-by-step rotation for drawing forward label-strips and feeding them downward through the dies, and reciprocating punches operating in conjunction with the dies to punch labels from said strips by a direct longitudinal movement, and by their continued movement to press the labels so punched out upon both ends of a spool simultaneously, as hereinafter more particularly described.

The invention also consists in novel mechanism employed for drawing forward or feeding the label-strips from reels on which they are wound, whereby only the proper length of strip is drawn forward after each operation of

the punches; of novel mechanism for applying adhesive substance—such as paste or mucilage—to the labels; in a novel means for preventing the dies from becoming smeared with the paste as the strips, with the paste applied to the labels, are passed through them, and in other novel combinations of parts and details of construction hereinafter described, and referred to in the claims.

In the accompanying drawings, Figure 1 is a front elevation of my improved machine. Figure 2 is a plan thereof. Figure 3 is a transverse vertical section upon a larger scale. Figure 4 is a longitudinal section of a part of the machine. Figure 5 is a plan of one of the label-strips and a part of the mechanism for feeding it and drawing it from the reel. Figure 6 is a horizontal section of one of the dies and its punch. Figure 7 is a longitudinal section through one of the feed-wheels, a paste-wheel, and a ratchet-wheel for feeding the label-strip. Figure 8 is a transverse section of the track or guideway. Figure 8* is a similar view on a larger scale, including upper and lower guards, hereinafter described. Figure 9 is another transverse section thereof, showing its supporting devices and devices for adjusting it and the spool-rest upward and downward. Figure 10 is a vertical section of one of the dies. Figure 11 is a plan and partial section thereof. Figure 12 is a detail plan view on the same scale as Fig. 3, illustrating a portion of the mechanism for applying adhesive substance or paste to the label-strips and for reciprocating the punches. Figure 13 is a vertical section in the same plane as Fig. 7, illustrating more completely the mechanism for applying paste. Figs. 14 and 15 are respectively a partly-sectional side view of a portion of one of the levers carrying a paste head or die, and an inverted plan of the face of such head or die; and Fig. 16 is a face view of one of the dies, whereby labels are cut from the strip.

Similar letters of reference designate corresponding parts in all the figures.

A designates a table or platform whereon the whole apparatus is mounted, and B designates a base-plate whereon the principal portion of the machine is arranged.

C C designate the track or guideway for the

spools. This track is composed of rails C C, which are provided with flanges *a*, on which the spools *b* rest, and which are adjustably secured to the rods *a' a' a'*, on which they may be adjusted toward and from each other and secured in different positions to receive spools of different lengths between them. In the flanges *a* of the guide-rails are formed notches or depressions *a³*, which constitute a spool-rest, and the guide-rails C may be adjusted upward and downward to bring the spool-rest *a³* into proper position. The rod *a²* is attached at its end at two collars or sleeves, *a⁴*, adapted to be adjusted up and down on screw-threaded posts *a⁵*, and secured in different positions by nuts *a⁶*, as best shown in Fig. 9.

Above the track or way C C is a guard, *a⁷*, which prevents spools from jumping out, and below said tracks or ways is a guard, *a⁸*, (shown in Fig. 3,) which prevents refuse matter from dropping down into the machine. The relation of these guards to the tracks or ways is shown most clearly in Fig. 8*.

Beyond the spool-rest *a³* the track or guide-way is extended, as shown in Fig. 3, so as to deliver the spools after labeling.

Below the track or way C is a slide or cross-head, D, mounted in or on a guide or slideway D', formed upon the frame of the machine, and adapted to be reciprocated by means of a connecting-rod, D², which receives motion from a crank, D³ on a driving-shaft, D⁴. The driving-shaft is mounted in bearings *b'*, and may be rotated by a belt upon fast and loose-pulleys D⁵ D⁶. The rod D² is connected with the cross-head D by a wrist-pin *b²*, and is continued for a considerable distance beyond the same, and in its projecting end is shown a piece or finger, *b³*, which may be adjusted upward and downward in the rod and secured in position by means of a set-screw, *b⁴*. The form of this piece or finger is clearly shown in Fig. 3, and the connecting-rod gives it both a rising and falling and a reciprocating motion. The finger or piece *b³* serves to push each spool *b* out of the spool-rest *a³* after its labels have been applied, and by rising between the spool which is in the rest and the one behind it the finger forms a stop for the remaining spools and eases or retards their descent, as it pushes the labeled spool from the rest. Upon the base-plate B are mounted two stocks, E, somewhat similar to the head and tail stocks of a lathe, and in said stocks are fitted sliding bars or spindles E', which are in line with each other and carry at their inner or adjacent ends punches *c*. By adjusting the track or guide-way vertically, as before described, the spool-rest *a³* is brought into such relation to the punches *c* that the punches will be concentric with the spool supported on the rest.

Attached to the adjacent ends of each stock E is a die, *c'*, wherein the punch *c* fits, and through which the label-strip F is drawn or passes in a vertical direction past the punch *c*. The two label-strips are best shown in

Figs. 1, 2, 4, and 5. The labels are denoted by dotted circles, and in the strips are register-holes *c²*, which will be hereinafter referred to. The strips F are drawn from reels F', (shown in Figs. 1 and 2,) and are first conducted through tension devices *c³*, thence through or between apparatus F², for drawing a proper length of strip from the reels at intervals, thence over and partly around feed-wheels F³, which I will hereinafter describe, and finally downward through the dies *c'*.

In order to receive spools of different lengths between the dies *c'*, the stocks E must be adjusted toward and from each other. This is done by means of screws *c⁴* on the base-plate B, and after adjustment the stocks are strongly secured in place by bolts *c⁵*.

Referring now to the mechanism for operating the punches, G designates elbow or bell-crank levers, fulcrumed at *c⁶*, and each having one arm projecting toward the punch-spindles E', and the other arm projecting toward and over the cross-head D. In the top of the cross-head D is a slideway or groove, *c⁷*, and each bell-crank lever is pivoted by a bolt, *c⁸*, to a block, *c⁹*, which can slide to and fro in the groove or slideway *c⁷* in the cross-head, as shown in Fig. 3, and more clearly still in the detail view, Fig. 12. The sliding blocks *c⁹* compensate for the arc described by the ends of the bell-crank levers G as they are oscillated or moved to and fro in a horizontal plane.

Upon each punch-spindle E' is adjustably secured a collar or hub, *c¹⁰*, having its upper and lower sides flat and parallel, and provided in said upper and lower sides with grooves or short slideways *c¹¹*.

Each bell-crank lever G is forked so as to embrace the collar or hub, and is pivoted to blocks *c¹²*, which are free to slide in the slideways or grooves *c¹¹* in a direction transverse to the punch-spindles E'. The collars or hubs *c¹⁰* are secured upon the spindles E' by set-screws *c¹³*, (shown in Figs. 1, 2, and 4,) and may be adjusted and secured in different positions on the spindles, so that the punches *c* will approach each other to just the required distance, and will press with the proper force on opposite ends of the spool *b*.

Concentric with each feed-wheel F³ is a paste-wheel, F⁴, rotating in a paste-box, F⁵, and the two paste-boxes are supplied with paste or other adhesive substance from reservoirs or elevated receptacles F⁶. Each feed-wheel F³ and paste-wheel F⁴ are mounted, as shown in Fig. 7, and also in Fig. 13, on a sleeve, *d*, to which they are secured rigidly so that they will turn therewith, and the said sleeve turns upon a fixed spindle or bolt, *d'*, secured rigidly at one end. Upon the sleeve *d* is also secured a ratchet-wheel, *d²*, whereby the sleeve and attached wheels may be turned, as I will now describe.

Upon each punch-spindle E' is secured a collar or stock-piece, G', (best shown in Fig. 4,) and each having in it a short slideway or

slot, d^2 , in which a sliding block, d^4 , may be adjusted by a screw, d^5 . To each block d^4 is pivoted a turning-pawl, d^6 , which, by a spring, d^7 , is held up in engagement with the ratchet-wheel d^2 , and hence it will be seen that as the punch-spindles E' are moved apart after performing their work they carry the turning-pawls d^6 with them, and so turn the ratchet-wheels d^2 , the feed-wheels F^3 , and the paste-wheels F^4 step by step.

The spring d^7 consists, simply, of a small spiral spring placed between the collar G' and the under side of the pawl d^6 in a position forward of the pivot-block d^4 .

Referring now to the mechanism for applying adhesive substance or paste to the labels, (shown best in Fig. 3,) H H designate two levers, which are fulcrumed at one end, d^{20} , in upwardly-extending projections d^8 on the cross-head D , and which are free to slide back and forth, as the cross-head moves, in guides d^9 , containing rollers d^{10} , on which the levers move, and upon which they are held down by springs d^{11} . These guides and rollers are both shown in Figs. 4 and 12, and one guide and its roller are shown in Figs. 3 and 13.

In the under sides of the levers H are depressions or recesses d^{12} d^{13} , and it will be understood that when by the longitudinal sliding movement of these levers the depressions d^{12} d^{13} come opposite the rollers d^{10} the levers will drop slightly, while at all other times they will be raised or elevated.

Upon the end of each lever H is a die or head, e , the face of which is concave in one direction to conform to the curvature of the feed-wheel F^3 and paste-wheel F^4 , and the face of which is grooved at e' , (see Fig. 3,) for a purpose hereinafter described.

The longitudinal movement imparted to the levers H by the cross-head D is equal to the distance from the middle of the paste-wheel F^4 to the middle of the feed-wheel F^3 , and by such movement of the levers the dies or heads e are carried from a position over the feed-wheels to a position over the paste-wheels, and vice versa. Supposing the levers H to be in the position shown in Fig. 3, and moving forward, it will be understood that this movement is continued until the depressions d^{12} reach the rollers d^{10} , whereupon the levers drop, and their dies or heads e fall upon the paste-wheels F^4 and receive a charge of paste. The levers then move back until the depressions d^{13} reach the rollers d^{10} , and then drop, so that the heads or dies e fall on the strips F and leave an imprint of paste on the labels which are then under them.

The feed-wheels F^3 are protected by hoods e^2 , which are slotted at e^3 and cut away at e^4 , (see Figs. 4 and 5,) so as to expose the strips to the action of the paste heads or dies e . The feed-wheels F^3 are provided with register-pins e^5 , which take into the holes e^3 in the strips, and so insure the proper register of the labels for the paste heads or dies e . By the move-

ment of the strips after being pasted the labels are brought opposite the punches e . By the movement of the punches the labels are cut from the strips, and as the punches continue their movement they press the labels on the ends of the spools and so affix them thereto.

Now, it will be easily understood that if the labels are pasted all over and drawn through the dies e' the latter would soon become smeared and clogged with paste, and this I desire to avoid. The paste heads or dies e being slotted or grooved at e' , as shown best in Figs. 14 and 15, do not cover the whole label with paste, but leave a narrow strip through each label in the direction in which the strip moves. The cutting portion of each die e' is formed by a plate or ring, e^{14} , to which the punch e is fitted, and above and projecting beyond or inward of the cutting-edge of this plate or ring is a narrow rib or projection, e^{15} . (Shown best in Figs. 10 and 11.) The position of the rib or projection e^{15} relatively to the cutting-edge of the plate e^{14} is best shown in Fig. 16. As the strip F is drawn through the die e' , the narrow portion of the strip, which is destitute of paste, is opposite the rib or projection e^{15} , and by bearing thereon the strip is held slightly away from the cutting-edge of the die, so that it will not rub across the said edge and so scrape off paste upon the die. The paste head or die e is perforated axially, as shown in Figs. 14 and 15, to "vent" it, and to thus prevent its pulling up the strip by atmospheric pressure when raised.

If the strips F were drawn by the feed-wheels F^3 directly from the reels F' , there would be a liability to too great a tension being produced on the paper by the feed-wheels, which might thus be torn by the pins of said wheels. To prevent this, I employ the drawing apparatus F^2 for each strip, and which I will now describe. This apparatus is supported by a standard, f , (shown in Fig. 1,) the upper end of which forms a bearing for a horizontal rock-shaft, f' , and to which is attached an arm, f^2 , which projects under the strip F . Upon one end of the rock-shaft f' is securely fixed an arm, f^3 , which projects over the strip F beyond the arm f^2 , and to the opposite end of the rock-shaft is secured an arm, f^4 , which is connected by a link, f^5 , with a collar, f^6 , on the punch-spindle E' , said collar being secured in place adjustably by means of a set-screw, f^7 . On the rock-shaft f' is loosely fulcrumed a lever, f^8 , one end of which is provided with an arm, f^9 , extending under the strip F beyond the arm f^3 , and on the other end of which is a weight, f^{10} , intended to almost balance the lever. The lever f^8 also has an arm or piece, f^{11} , projecting over the strip directly above the arm f^2 . Supposing the punch-spindle E' to be moving outward or returning after performing its work, it will be obvious that the arm f^3 will be simply raised away from the strip F , and the latter will not be affected. When, however, the spindle

makes its inward movement, the rock-shaft f' will be oscillated, so as to bring the arm f^3 down on the strip and depress it, and the depression of the strip will produce a downward pressure on the arm f^9 , and thereby cause the arm f^{11} to bite down on the strip F and to hold the latter tightly grasped between the arm f^{11} and the arm f^2 . Thus the descent of the arm f^3 is caused to draw the strip forward from the reel, and not backward from the feed-wheel.

What I claim as my invention, and desire to secure by Letters Patent, is—

1. The combination of oppositely-arranged dies c' , a spool-rest, a' , between them, the feed-wheels F^3 , arranged above said dies, having a step-by-step rotation for drawing forward label-strips and feeding them downward through said dies, and reciprocating punches e , operating in conjunction with the dies to punch labels from said strips by a direct longitudinal movement and by their continued movement to press the labels so punched out upon both ends of a spool simultaneously, substantially as herein described.

2. The combination, with the oppositely-arranged dies and the spool-rest between them, of punches for punching labels from the strips and pressing them upon spools, mechanism for reciprocating the punches, feed-wheels for feeding the strips through the dies, ratchet-wheels moving with the feed-wheels, and turning-pawls carried by the punch-spindles for operating on said ratchet-wheels, substantially as herein described.

3. The combination, with the dies c' and the punches and spindles e E' , of the feed-wheels F^3 and attached ratchet-wheels d^2 , the collars G' , provided with slots d^3 , the blocks d^4 , and the pawls d^6 , pivoted thereto, and the screws d^5 , for adjusting said blocks and pawls, substantially as herein described.

4. The combination, with the oppositely-arranged dies and punch-spindles and a spool-rest between them, of feed-wheels for feeding the label-strips through the dies, reels on which the strips are wound, and mechanism, substantially such as described, located between said feed wheels and reels, and operated from the said spindles to draw from the reels a length of strip suitable for each feeding operation of the feed-wheels, substantially as described.

5. The combination of the support f and the

arm f^2 , projecting below the label-strip, the rock-shaft f' and its arm f^3 , projecting over the label-strip beyond the arm f^2 , the lever f^8 , provided with the arms f^9 f^{11} , and means for oscillating said rock-shaft f' , substantially as herein described.

6. The combination of the feed-wheel F^3 , the paste-wheel F^4 , the ratchet-wheel d^2 , the sleeve d , whereon said wheels are all secured, the inner rod or bearing, d' , for the sleeve, and the turning-pawl engaging with said ratchet-wheel, substantially as herein described.

7. The combination, with the oppositely-arranged dies and punches and a spool-rest between them, of the feed-wheels and paste-wheels arranged in line, levers carrying the paste-dies, and mechanism for imparting to said levers a reciprocating motion to carry their dies from the paste-wheels to the feed-wheels, and vice versa, and a rising-and-falling motion to bring them into contact with the paste-wheels and the label-strips upon the feed-wheels, substantially as herein described.

8. The combination, with oppositely-arranged dies and punches and the feed-wheels and paste-wheels arranged in line, of the levers H , having depressions or offsets d^{12} d^{13} , and carrying paste-dies e , the guides d^8 , and bearing-wheels d^{10} , and mechanism for reciprocating said levers, substantially as herein described.

9. The combination of the oppositely-arranged dies and punches c' c' , the feed-wheels F^3 , and paste-wheels F^4 , having a step-by-step rotary motion, the track or guideway C C , the cross-head D , the connecting-rod D^2 , and its finger b^3 , the levers H , with their depressions d^{12} d^{13} , and paste-dies e , the guides d^8 , and bearing-wheels d^{10} , substantially as herein described.

10. The combination, with the dies having the faces c^4 , and the ribs c^{15} , projecting inward beyond the cutting-edges of the dies for holding the label strips out of contact with said cutting-edges, the reciprocating punches fitted to the dies, the paste-dies e , provided with grooves e' in their faces, and mechanism, substantially such as described, for operating said paste-dies, substantially as and for the purpose herein set forth.

W. R. LANDFEAR.

Witnesses:

FREDK. HAYNES,
ED. L. MORAN.